

Luxman

USB D/A CONVERTER

DA-200

Owner's Manual

Contents

Precautions	1
Features of This Unit	2
Names and Functions	4
Connections	8
Operations	10
Block Diagram	12
Specifications	13
Before Asking for Repair Services	14

Installation place

- Choose a stable place near the devices that are to be used in combination with this unit.
- Do not install this unit near a television or color monitor. Keep this unit away from such devices as cassette decks that are subject to magnetism.

Avoid the following locations for installation.

- Locations exposed to direct sunlight
- Places subject to humidity and with less ventilation
- Places where are extremely hot or cold
- Places subject to strong vibration
- Places subject to dust
- Places subject to oil, steam, and heat (such as kitchens)

To avoid heat emission

Do not place this unit on such device as an amplifier that may emit heat. If the unit is installed on a rack, install the unit as distantly as possible from where the amplifier is installed so as to avoid heat emission from the amplifier and other audio devices.

Power off this unit when it is not used.

Depending on the condition of radio waves emitted during television broadcasting, interference fringes may appear on the television monitor, but that is not a malfunction. In such a case, power off the unit. There may also be a case where noises are heard on the radio due to radio wave interference.

Notice when handling optical digital cables

- Do not fold the cables. For storage, wind each cable to make a coil whose diameter is approx. 15 cm or larger.
- For connection, insert the cable connectors firmly into the terminals of this unit and the other device.
- Use the cables whose each length is 3 m or less.
- When the cable connectors get dusty, wipe the dust away with a dry soft cloth before inserting into the terminals.

Cleaning

- Usually, wipe the unit with a dry soft cloth. When the dirt is hard to remove, dip soft cloth in detergent diluted 5 or 6 times with water, wring it well, and remove contaminants. Then, remove the moisture with dry cloth.
- Do not use a solvent like alcohol, benzine, thinner, or pesticide because such a substance can damage the exterior. In addition, do not let this unit contact a rubber or plastic form for a long time. That may damage the cabinet surface of the unit.
- When using a chemical cloth for cleaning, read the caution provided with the chemical cloth product.
- Before cleaning, unplug the power cord from the AC outlet.

Precautions in connecting with other components

When connecting this unit to input devices such as a CD player, an SACD player, a tuner, and a recorder, be sure to turn off the power of this unit and all other connected devices. Failure to observe this may generate a strong noise resulting in speaker damage or cause a malfunction.

The pin-plug to be inserted in each input terminal of this unit shall be pushed in firmly. If the grounding terminal is inadequately connected, noises including hum may be generated, resulting in an adverse S/N ratio.

Repair and adjustment

When repairs or adjustments are needed, please ask the dealer where you bought the unit.

Features of This Unit

Compact chassis design

This unit is a 2-channel PCM D/A converter that has a compact body as small as B4-paper size.

USB input that is applicable to 96 kHz / 24 bit

Introduction of a B-type USB input terminal that allows the input of USB digital audio signal from a PC/Mac.

Circuits whose grade is equivalent to D-05

High-performance circuits, equivalent to those of the SACD player D-05, are used for the peripheral circuit of DAC and the analog output amplifier.

DD converter function

All the digital inputs including USB are converted into digital outputs as the S/PDIF signals.

Built-in headphone amplifier

This unit is equipped with a high-grade headphone amplifier circuit.

Built-in pre-amplifier circuit

This unit is equipped with a newly-designed pre-amplifier circuit that is effective for unbalanced variable level outputs.

Balance output

This unit is equipped with XLR balance output terminals with full-fledged balanced-structure circuits that are effective for digital inputs.

PCM1792A manufactured by Burr-Brown

For the DAC chip, this unit applies PCM1792A manufactured by Burr-Brown that has been used for the Luxman new D-series SACD players.

Compatibility with high-resolution formats

This unit has the compatibility with digital inputs of 32 kHz to 192 kHz (32 kHz to 96 kHz for USB) sampling frequencies and numbers of quantization bits of 16 bit, 20 bit, and 24 bit (16 bit, 24 bit for USB).

Built-in sampling rate converter

Digital input signals are processed for up-sampling at the time of D/A conversion.

Jitter reduction function

The dedicated clock unsynchronized with inputs can reduce jitter.

7-segment LED

The sampling frequency of a digital input can be displayed on the 7-segment LED with a high level of visibility.

Input/output terminals

Introduction of an 18 mm pitch RCA terminal with gold plating and a high-grade XLR terminal manufactured by Neutrik allows even a line cable with large plug to be connected.

Introduction of original technologies

Our traditional round pattern board, internal wiring with the spiral wrap shielding, and original custom-made parts are fully and luxuriously introduced.

Driverless connection with a PC/Mac

For the USB connection with a PC/Mac*1, this unit has the compatibility with standard drivers for operating systems. (Microsoft Windows XP*2 or later / Mac OS X*1 or later)

*1 Mac and Mac OS are trademarks of Apple Inc., registered in the U.S. and other countries.

*2 Microsoft and Windows are either registered trademarks or trademarks of Microsoft Corporation in the United States and/or other countries.

Names and Functions

Front panel

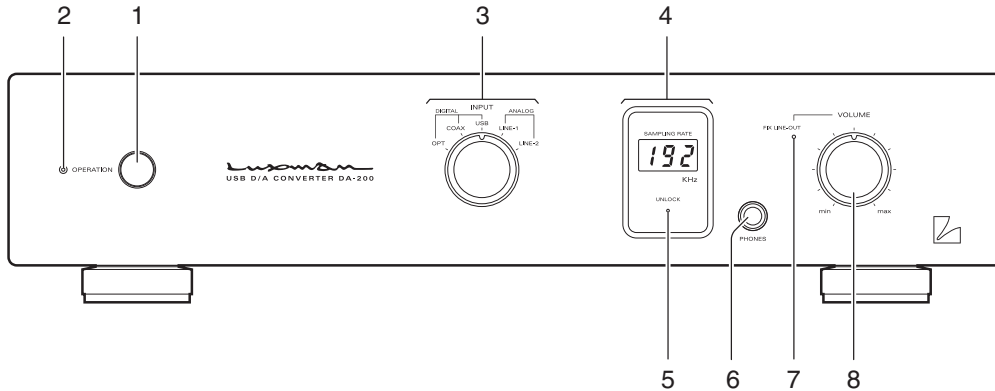

1. Operation switch (OPERATION)

Toggles the power on and off.

When wiring or connection is performed, be sure to turn off this switch.

2. Operation indicator (OPERATION)

Blinks in the time of muting mode when the operation switch is turned on and lights up when the operation state is activated afterward.

3. Input selector (INPUT)

Selects an input device connected to each input terminal. The input selector has 5 positions consisting of OPT, COAX, USB, LINE-1, and LINE-2 from left to right that correspond to each input terminal on the rear panel. To select an input source, set the pointer of the selector to the position of the source to be reproduced.

Input: Digital output from a PC/Mac, a CD player, an SACD player, a DVD player, and other such devices (OPT/COAX/USB)

Analog line output from a CD player, an SACD player, a tuner, a DVD player, a TV, and other such devices (LINE-1, LINE-2)

4. Sampling frequency LED (SAMPLING RATE)

Displays the sampling frequency of a digital input signal from a device connected to the digital input terminal (OPT/COAX/USB). When a digital input is selected from OPT/COAX/USB by rotating the input selector and the digital input signal from the digital device is synchronized with this unit, the sampling frequency of the signal is displayed on this LED.

When no digital signal is input or no synchronization is established even with a digital signal input, the digital signal unlock indicator lights up, and the sampling frequency is not displayed on the LED.

The following sampling frequencies can be displayed.

When a signal is input to the USB terminal:

32 kHz, 44.1 kHz, 48 kHz, 96 kHz

When a signal is input to the OPT/COAX terminal:

32 kHz, 44.1 kHz, 48 kHz, 88.2 kHz,
96kHz, 176.4 kHz, 192 kHz

5. Digital signal unlock indicator (UNLOCK)

When a digital input is selected from OPT/COAX/USB by rotating the input selector and the digital input signal from the digital device is not synchronized with this unit, this indicator lights up.

6. Headphone jack (PHONES)

When you want to use a stereo headphone, insert the headphone standard plug in this output jack.

If a mini size plug is used for your headphone, use a mini to standard adapter that is an accessory of the headphone or available on the market.

7. Line output level fix indicator (FIX LINE-OUT)

Lights up when the line output level fix/variable selection switch (FIX/VARIABLE) on the rear panel is set to FIX.

When this indicator lights, the volume control of this unit cannot adjust the line output level. (The sound volume of the headphone can be adjusted regardless of the state of the selection switch.)

8. Volume control (VOLUME)

Adjusts the sound volume of the device connected to the analog unbalance output terminals (RCA) when the sound volume of the headphone or the line output level fix/variable selection switch (FIX/VARIABLE) on the rear panel is set to VARIABLE. Sound is not generated when this control is rotated counterclockwise to the end, and then, the sound volume gradually becomes higher when the control is slowly rotated clockwise.

The line output level (RCA) is not changed even if the control is rotated when the line output level fix/variable selection switch (FIX/VARIABLE) on the rear panel is set to FIX. Besides, the line output level (XLR) is always fixed regardless of the state of the line output level fix/variable selection switch (FIX/VARIABLE).

Relational table of the input and output of DA-200

Output Input	Headphone output	Line output		Digital output
		RCA	XLR	OPT/COAX
Digital input	Variable	Variable/ Fixed	Fixed	Available
Analog input	Variable	Variable/ Fixed	Not available	Not available

Names and Functions

Rear panel

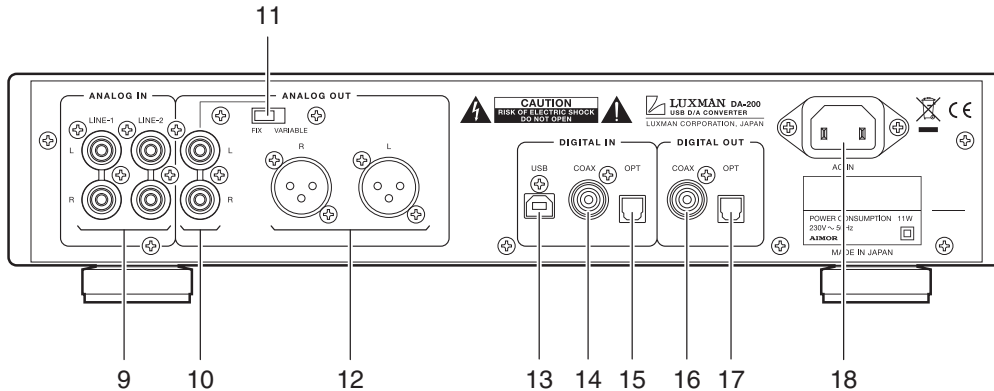

9. Analog input terminals (LINE-1/LINE-2)

These are RCA input terminals used for the line level input signals from a CD player, an SACD player, a tuner, a DVD player, a TV, and other such devices. The input sensitivity is 290 mV, and the impedance is 24 kohms. The functions of LINE-1 and LINE-2 are the same.

The playback signals from a device connected to these terminals are not output from the analog balance output terminals (XLR) or digital output terminals (OPT/COAX).

10. Analog unbalance output terminals (RCA)

These are RCA output terminals used for the unbalanced playback output signals from this unit.

When the line output level fix/variable selection switch (FIX/VARIABLE) is set to VARIABLE, the output level varies depending on the state of the volume control (VOLUME) on the front panel.

11. Line output level fix/variable selection switch (FIX/VARIABLE)

Toggles the level of the playback signals from the analog unbalance output terminal (RCA) between fixed and variable.

When this switch is set to FIX, the line output level fix indicator (FIX LINE-OUT) lights up to indicate that the output level from the analog unbalance output terminal (RCA) is fixed and cannot be adjusted with the volume control.

When the switch is set to VARIABLE, the output level of volume control on the front panel and that of the analog unbalance output terminal (RCA) changes interlockingly.

(The sound volume of the headphone can be adjusted regardless of the state of the selection switch.)

Besides, the level of the playback signals from the analog balance output terminals (XLR) is always fixed regardless of the state of the selection switch.

When the selection switch is toggled, the line output level may greatly change.

Be careful of the sudden change in the sound volume.

12. Analog balance output terminals (XLR)

These are XLR output terminals used for the balanced playback output signals from this unit.

These terminals does not output the playback signals from a device connected to the analog input terminals (LINE-1/ LINE-2) of this unit. Besides, the level of the playback output signals is always fixed regardless of the state of the line output level fix/variable selection switch (FIX/VARIABLE).

The following are the polarities of output terminals of this unit.

1. GROUND
2. COLD (-)
3. HOT (+)

13. Digital input terminal (USB)

This is a USB 1.1 (B-type) input terminal used for the digital input signal from such device as a PC/Mac using a USB cable.

The terminal is applicable to the following data.

Sampling frequency: 32 kHz, 44.1 kHz, 48 kHz,
88.2 kHz, 96kHz, 176.4 kHz,
192 kHz

Number of quantization bits: 16 bit, 24 bit

However, a digital signal of 88.2 kHz, 176.4 kHz, or 192 kHz is input, the sampling frequency is internally converted into 96 kHz.

14. Digital input terminal (COAX)

This is an RCA input terminal used for the digital input signal from such device as a CD player equipped with digital output terminals using a coaxial digital cable.

The terminal is applicable to the following data.

Sampling frequency: 32 kHz, 44.1 kHz, 48 kHz,
88.2 kHz, 96kHz, 176.4 kHz,
192 kHz

Number of quantization bits: 16 bit, 20 bit, 24 bit

15. Digital input terminal (OPT)

This is a TOS-LINK input terminal used for the digital input signal from such device as a CD player equipped with digital output terminals using an optical digital cable.

The terminal is applicable to the following data.

Sampling frequency: 32 kHz, 44.1 kHz, 48 kHz,
96 kHz, 176.4 kHz, 192 kHz

Number of quantization bits: 16 bit, 20 bit, 24 bit

16. Digital output terminal (COAX)

This is an RCA output terminal used to output the digital signal that has been input from the digital input terminal (OPT/ COAX/USB).

The digital input signal selected by rotating the input selector is output. The sampling frequency and the number of quantization bits of the digital output signal are the same as those of the input signal.

The playback signals from analog input terminals (LINE-1/ LINE-2) are not output from this terminal.

17. Digital output terminal (OPT)

This is a TOS-LINK output terminal used to output the digital signal that has been input from the digital input terminal (OPT/COAX/USB).

The digital input signal selected by rotating the input selector is output. The sampling frequency and the number of quantization bits of the digital output signal are the same as those of the input signal, but since the channel status indicating the digital format is reset only when the signal is output from this terminal, the sampling frequency may be displayed as 44.1 kHz on the D/A converter connected to this unit.

The playback signals from analog input terminals (LINE-1/ LINE-2) are not output from this terminal.

Relational table of the input and output of DA-200

Input \ Output	Headphone output	Line output		Digital output
		RCA	XLR	OPT/COAX
Digital input	Variable	Variable/ Fixed	Fixed	Available
Analog input	Variable	Variable/ Fixed	Not available	Not available

18. AC inlet (AC IN)

Connects the accessory power cable. The power shall be supplied from a household wall outlet.

Connections

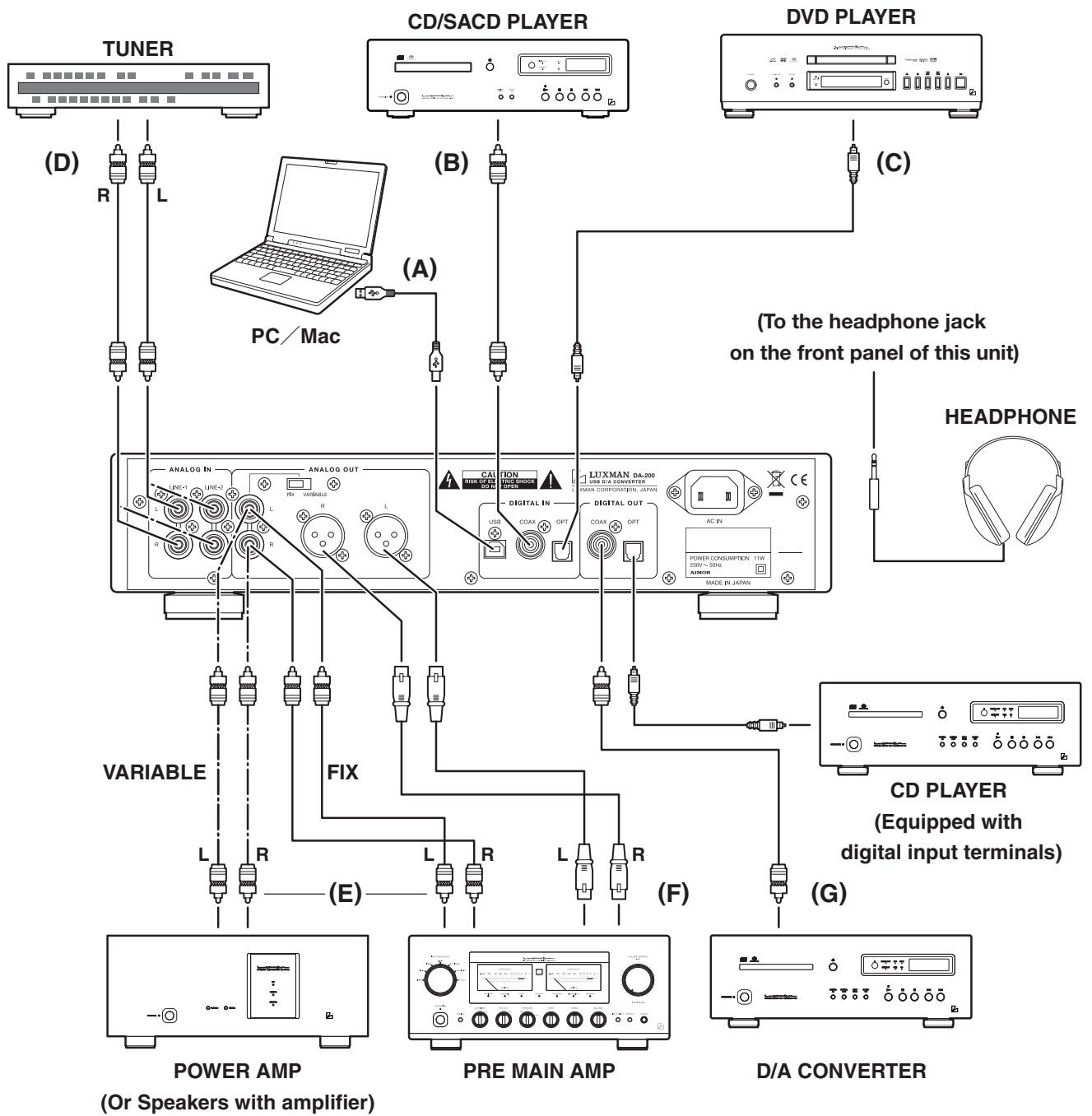

How to connect power supply

Use the accessory power cable and insert the AC plug in an outlet on the wall in the room where the unit will be installed.

How to connect input devices

1. Digital connection from a PC/Mac (Refer to "A" in the connection diagram.)

Connect between the USB 1.1 (A-type) input terminal of the PC/Mac and the USB 1.1 (B-type) input terminal of this unit with a USB cable.

The PC/Mac will automatically recognize this unit, and the unit will be ready to operate.

2. Digital connection from such device as a CD player (Refer to "B" and "C" in the connection diagram.)

Connect between the (coaxial or optical) digital output terminal of a CD player, an SACD player, a DVD player, and other such devices and the digital input terminal (COAX/OPT) of this unit with a coaxial digital cable and an optical digital cable.

This terminal has a shutter. Direct the cable connector correctly when inserting the cable into the terminal. If the cable connector is inserted forcibly with the wrong direction, the terminal may be deformed, and the shutter may not be able to close even after cable disconnection.

Upper side



The optical terminals are directed as illustrated.

Lower side

3. Analog connection from a CD player (Refer to "D" in the connection diagram.)

Connect between the analog output terminals of a CD player, an SACD player, a tuner, a DVD player, a TV, and other such devices and the analog input terminals (LINE-1/LINE-2) of this unit with 2 (R and L) RCA pin-plug cables.

How to connect output devices

1. Unbalanced connection with such device as a pre-main amplifier (Refer to "E" in the connection diagram.)

Connect between the analog unbalance output terminals (RCA) of this unit and the unbalance input terminals of such device as a pre-main amplifier with 2 (R and L) RCA pin-plug cables.

At this connection, the sound volume of the output signal change in accordance with the state of the line output level fix/variable selection switch (FIX/VARIABLE).

FIX / VARIABLE selection switch	FIX LINE-OUT indicator	Sound volume of the output signal	Such device as an amplifier to be connected
FIX	on	Always fixed	Pre-main amplifier
VARIABLE	off	Interlocked with the volume control	Power-amplifier / Speakers with amplifier

2. Balanced connection with such device as a pre-main amplifier (Refer to "F" in the connection diagram.)

Connect between the analog balance output terminals (XLR) of this unit and the balance input terminals of such device as a pre-main amplifier with 2 (R and L) XLR balanced cables.

The line output level fix/variable selection switch is activated only for the analog unbalance output. The sound volume of the analog balance output is always fixed regardless of the state of the selection switch.

3. Digital output to such device as another D/A converter (Refer to "G" in the connection diagram.)

Connect between digital output terminal (COAX/OPT) of this unit and such devices as a D/A converter and a CD player equipped with digital input terminals with a coaxial digital cable and an optical digital cable.

Operations

This unit is a D/A converter. Any operations for sound reproduction are performed with such input device as a PC/Mac or CD player connected to the input terminals.

Before operation

1. Ensure that the connections are correctly performed. (Normal playback cannot be achieved with wrong connections of R and L.)
2. After ensuring that the volume control has been rotated counterclockwise to the end and the sound volume is at the minimum level, press the operation switch to turn on the power of this unit.

Sound reproduction of a device connected to a digital input terminal (Analog output)

1. Select an input device to be reproduced with the input selector. (OPT/COAX/USB)
2. When the input devices starts reproduction, the digital signal unlock indicator (UNLOCK) turns off, and the sampling frequency of the playback signal is displayed on the LED.

If the digital signal is not normally input to the unit, the digital signal unlock indicator (UNLOCK) lights up, and signal is not output.

3. If the line output level fix/variable selection switch (FIX/VARIABLE) is set to FIX and if such device as a pre-main amplifier is connected to the analog unbalance output terminals (RCA) or the analog balance output terminals (XLR), adjust the sound volume with the volume control of the output device.

If the line output level fix/variable selection switch (FIX/VARIABLE) is set to VARIABLE and if such device as a power-amplifier or speakers with amplifier is connected to the analog unbalance output terminals (RCA), adjust the sound volume with the volume control of this unit.

Sound reproduction of a device connected to an analog input terminal (Analog output)

1. Select an input device to be reproduced with the input selector. (LINE-1/LINE-2)
2. If the line output level fix/variable selection switch (FIX/VARIABLE) is set to FIX and if such device as a pre-main amplifier is connected to the analog unbalance output terminals (RCA) or the analog balance output terminals (XLR), adjust the sound volume with the volume control of the output device.

If the line output level fix/variable selection switch (FIX/VARIABLE) is set to VARIABLE and if such device as a power-amplifier or speakers with amplifier is connected to the analog unbalance output terminals (RCA), adjust the sound volume with the volume control of this unit.

FIX / VARIABLE selection switch	FIX LINE-OUT indicator	Sound volume of the output signal	Such device as an amplifier to be connected
FIX	on	Always fixed	Pre-main amplifier
VARIABLE	off	Interlocked with the volume control	Power-amplifier / Speakers with amplifier

How to use the digital output

The playback signal that is input from a digital device to this unit can be output from a digital output terminal to such devices as another D/A converter and a CD player equipped with digital input terminals.

A CD player equipped with no USB input terminals can receive digital signal that is input from the USB input terminal of this unit by connecting between a digital input terminal (OPT/COAX) of the player and a digital output terminal (OPT/COAX) of the unit.

1. Select an input device to be reproduced with the input selector. (OPT/COAX/USB)
2. Adjust the sound volume with the volume control of the connected system device.

The digital output terminal does not output the playback signals from a device connected to the analog input terminals (LINE-1/LINE-2) of this unit.

How to use the headphone output

Insert the standard plug of a headphone into the headphone jack (PHONES) on the front panel of this unit while the volume control is rotated counterclockwise to the end. Start the reproduction of the input device, and rotate the volume control slowly clockwise to your favorite sound volume.

When the power is toggled between on and off, the input selector is changed over, or the headphone plug is connected or disconnected, rotate the volume control counterclockwise to the end to set the minimum sound volume.

If the headphone is used for a long time at a high sound volume, that may cause hearing loss.

Applied use of the analog output terminals

If the line output level fix/variable selection switch (FIX/VARIABLE) is set to VARIABLE and the analog unbalance output terminals (RCA) of this unit and the main in terminals (MAIN IN) of such device as a pre-main amplifier (such as Luxman L-505u) equipped with the separate function, the pre-amplifier section can be upgraded to a newly-designed pre-amplifier circuit.

Block Diagram

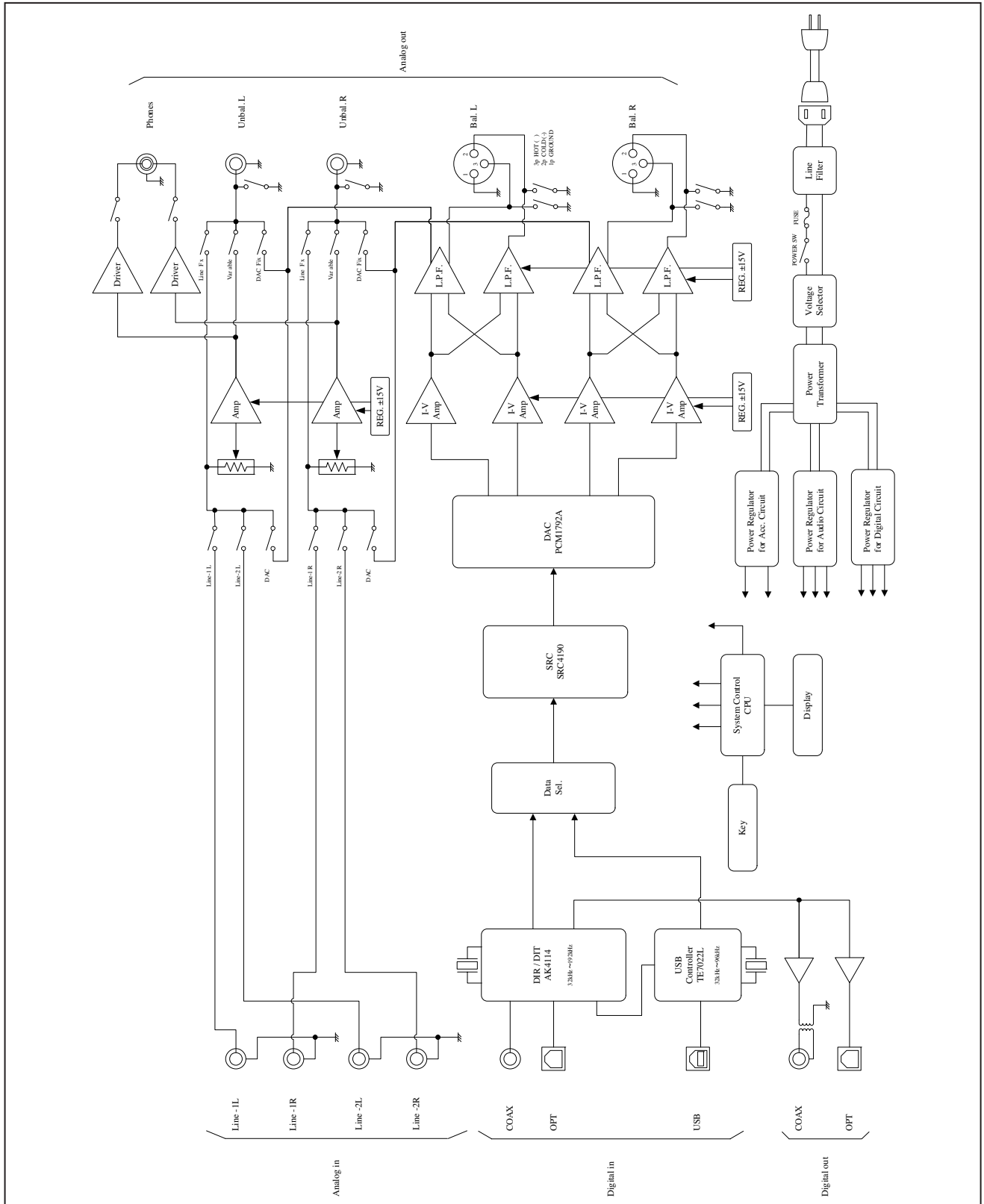

Specifications

USB D/A CONVERTER DA-200

Format	2-channel, USB D/A converter		
Ambient operating temperature	+5 °C to +35 °C		
Line input	Input sensitivity/input impedance	290mV / 24kΩ	
Audio output characteristics	Output voltage / output impedance	UNBALANCE terminal (RCA terminal) Fixed output 2.5 Vrms/400Ω UNBALANCE terminal (LINE terminal) Variable output 1.0 Vrms/400Ω BALANCE terminal (XLR terminal) 2.5 Vrms/600Ω PHONE terminal (Standard plug) 130mW + 130mW (600Ω) 80mW + 80mW (32Ω), 40mW + 40mW (16Ω)	
	Maximum output	UNBALANCE terminal (RCA terminal) Variable output 10 Vrms	
	Frequency response	DIGITAL IN 4 Hz to 20 kHz (+0, -0.4 dB) DIGITAL IN 2 Hz to 60 kHz (+0, -3.0 dB) ANALOG IN 10 Hz to 20 kHz (+0, -0.1 dB) ANALOG IN 3 Hz to 130 kHz (+0, -3.0 dB)	
	Total harmonic distortion	DIGITAL IN 0.0009 % / Unbalanced DIGITAL IN 0.0006 % / Balanced ANALOG IN 0.003 % / 1kHz (flat)	
	S/N ratio	DIGITAL IN 119 dB ANALOG IN 103 dB	
	Dynamic rang	DIGITAL IN 120 dB	
	Channel separation	DIGITAL IN 119 dB	
	Coaxial digital input	0.2 to 2.5 Vp-p	
	Optical digital input	-14.5 to -24 dBm	
	Digital input	USB input (Applicable OS)	Microsoft Windows XP or later, Mac OS X or later
Sampling frequency		OPT/COAX input : 32 kHz, 44.1 kHz, 48 kHz, 88.2 kHz, 96 kHz, 176.4 kHz, 192 kHz (16 bit, 20 bit, 24 bit) USB input : 32 kHz, 44.1 kHz, 48 kHz, 96 kHz (16 bit, 24 bit)	
Digital output	Coaxial digital output	RCA terminal 0.5 Vp-p/75Ω	
	Optical digital input	Optical digital terminal -15 ~ -21 dBm	
Accessories	<ul style="list-style-type: none"> • Power cable • Safety cautions • Owner's Manual 		
Power supply voltage	AC230 V, 50 Hz		
Power consumption	11 W		
Weight (Main unit)	5.1 kg		
Dimensions	364 (W) × 81 (H) × 257 (Knobs (14 mm) and terminals (8mm) included) (D) mm		

* Specifications and appearance are subject to change without notice.

Before Asking for Repair Services

While the unit is used, an unusual phenomenon may be confused as a malfunction for a certain reason. Prior to asking us for repair services, please check the table below and read the instruction manual for the subsidiary devices. If the cause of the malfunction cannot be identified, please contact your dealer. Besides, such personal computer as a PC/Mac connected to the unit and the software that operates on the PC/Mac (operations and settings included) are not supported.

Problem	Cause/Solution	Ref. page
No power is supplied even though the operation switch is pressed.	· Connect the power cable to the AC inlet (AC IN) and the AC outlet firmly.	9
No sound is generated. / Sound volume is too low.	· Connect the input devices, amplifier, speakers, and headphone correctly.	8~9
	· Set the input selector to the source to be reproduced.	10
	· When you are listening to the sound of a headphone or the variable line output (unbalanced), adjust the sound volume with the volume control of the unit.	10~11
	· When you are listening to the sound of a fixed line output (unbalanced) or the balance output, adjust the sound volume with the volume control of the connected amplifier.	10~11
No sound is generated. / Sound volume is too low. (Digital input)	· Connect digital cables correctly.	8~9
	· If the USB is selected as an input source, select this unit (DA-200) as the output destination by configuring the sound setting of a PC/Mac.	Refer to the instruction manual of the PC/Mac or the software in use.
	· If the unit (DA-200) cannot be selected even when trying the solution above, reconnect the USB cable.	
	· If the USB is selected as an input source, adjust the sound volume by configuring the sound setting of a PC/Mac.	
	· If the USB is selected as an input source, adjust the sound volume on a player software of a PC/Mac.	
	· Ensure that the sampling frequency and the number of quantization bits of the reproduced digital signal are applicable to this unit.	7
	· Ensure that the digital signal unlock indicator (UNLOCK) does not light up. (When the digital signal from the digital device is not synchronized with this unit, the source may not be reproduced.)	5
Humming sound (boon or zzz noise) is generated.	· Insert the RCA pin-plugs of the line cables firmly.	8
	· Induction noise may be picked up from the power transformer of another device. Install this unit distantly from the other device.	
	· When you are listening to the sound of a headphone, arrange the headphone cable and the power cable so that they are not laid too close.	

This unit may not work normally when the unit is subject to external influence such as static electricity. In such a case, the unit can work normally by unplugging the power cable once and plugging it again. If the cause of malfunction cannot be identified, please contact your dealer.

MEMO

luxman
USB D/A CONVERTER DA-200

MEMO

